

Basics of Vehicle Dynamics

Module H4

Steering Systems Characteristics

- King pin axis geometry
- Ackerman error
- Steering wheel systems

INTRODUCTION

Structural arrangement :

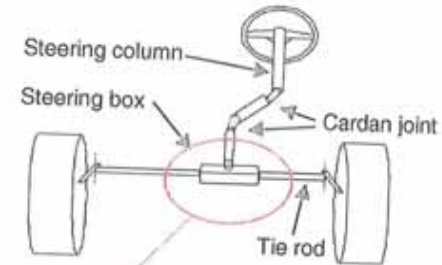

Pinion support bearings:

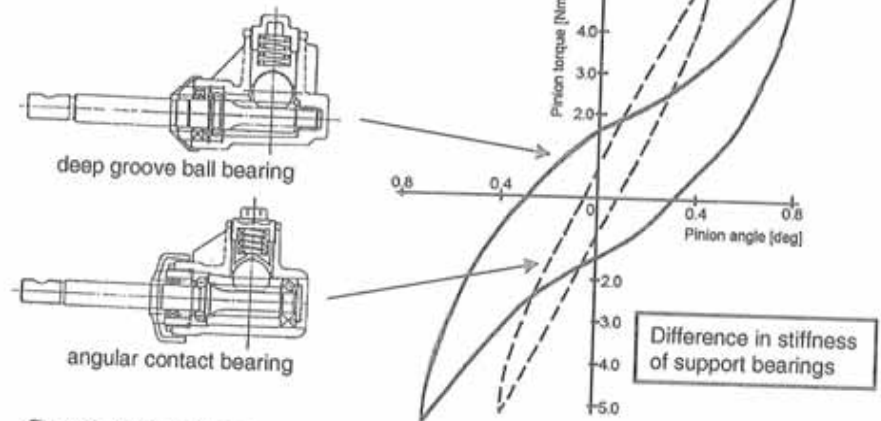

Steering functional map :

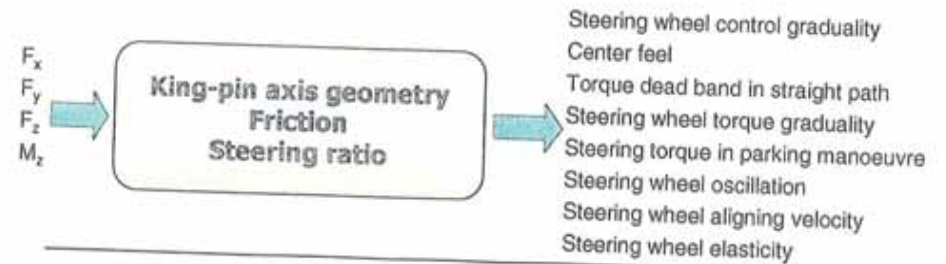

POWER STEERING

- Hydraulic
- Electric

Hydraulic power steering

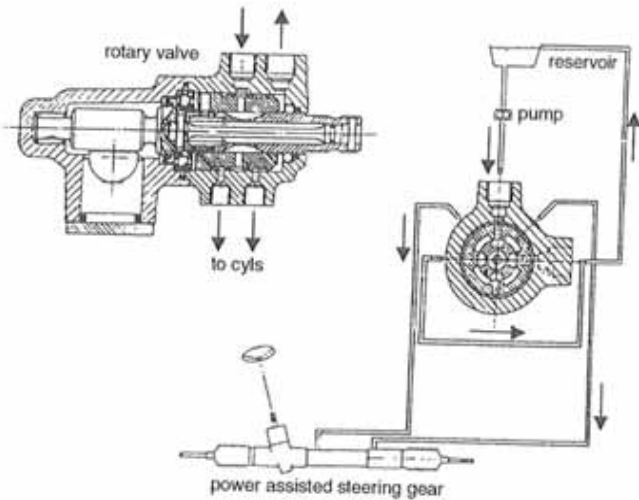

Slave curve

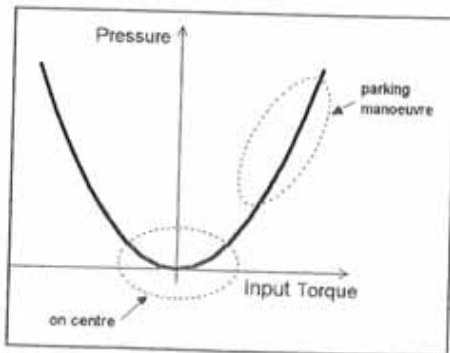

Tachymetric slave curve

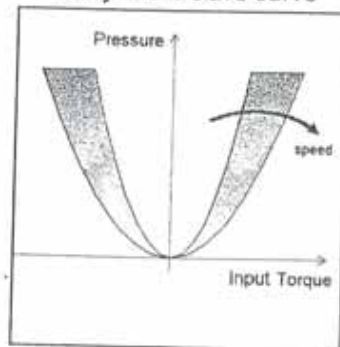

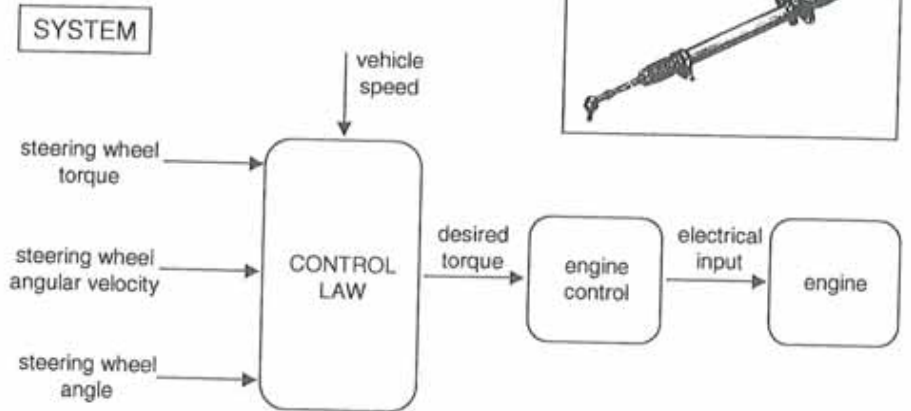

Electric power steering

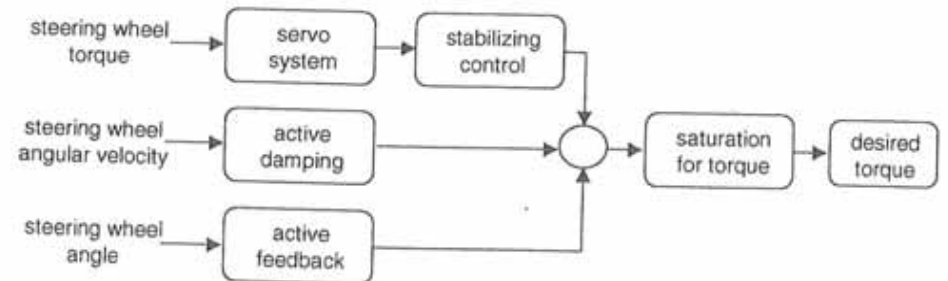

CONTROL LAW



FRICITION

- Hysteretical  Steering column, steering box, suspension links
- Viscous  Steering box
- Coulombic  Steering box, suspension links

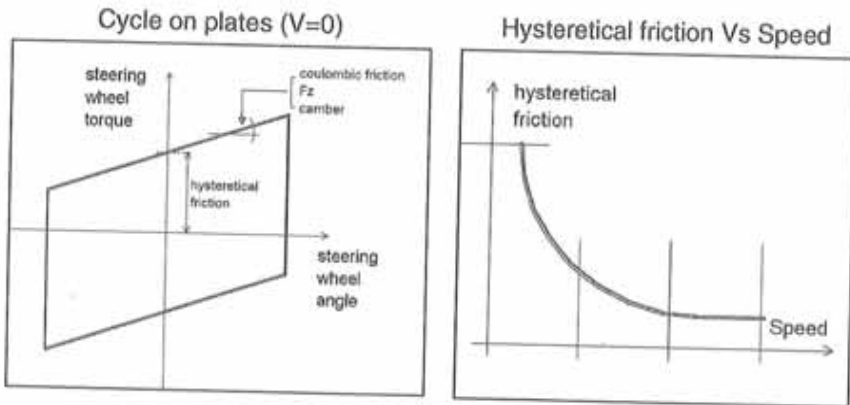

Hysteretical friction distribution in cycles on plates

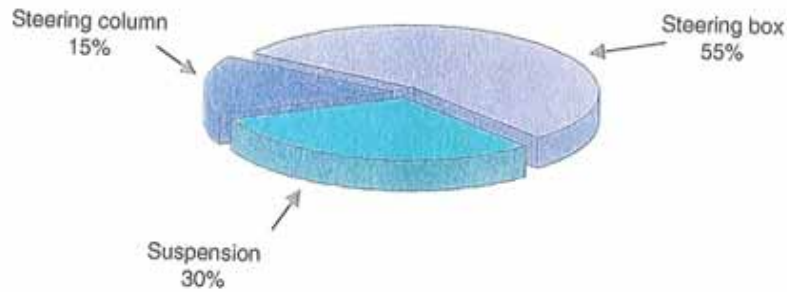

King-pin axis geometry

CASTER ANGLE

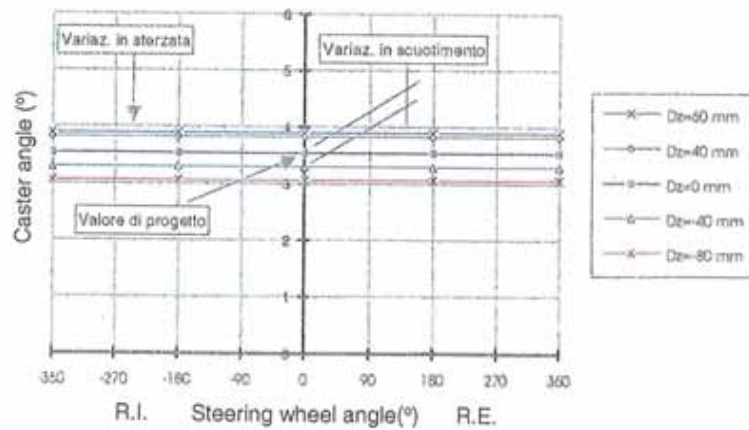
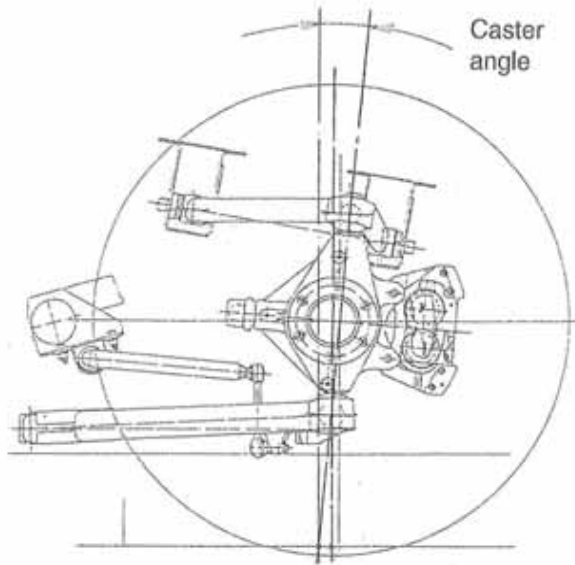

CASTER ANGLE

CASTER ANGLE INITIAL VALUE INFLUENCES:

- Steering camber change and king-pin inclination negative effect compensation
- Mechanical trail value

VARIATION IN KINEMATIC RIDE HEIGHT INFLUENCES:

- Mechanical trail variation
- Bump toe variation
- Comfort and stability due to the dynamic reactions of moving masses
- Suspensions - ABS compatibility
- Braking quality in uneven ground

STEERING CAMBER COMPENSATION

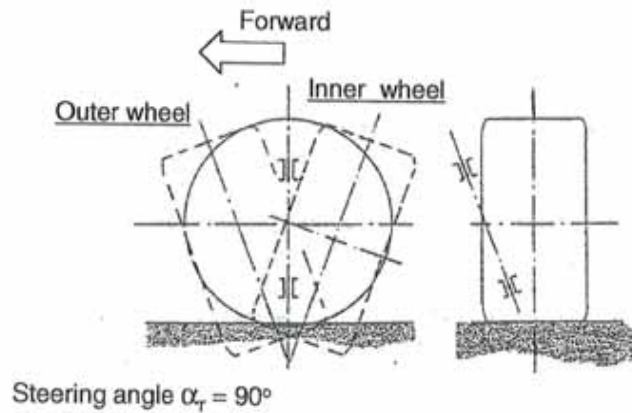
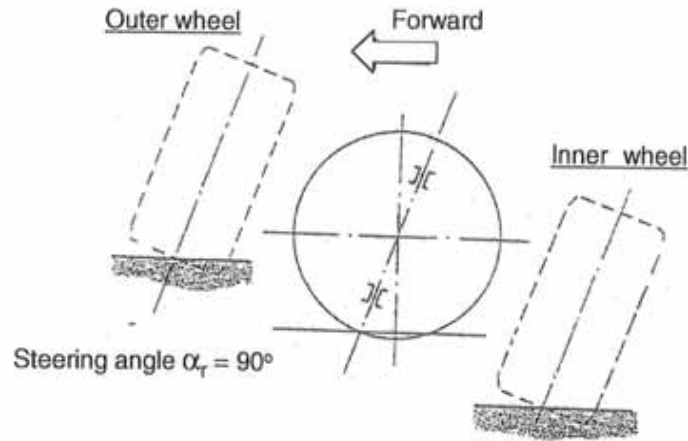

KING-PIN INCLINATION

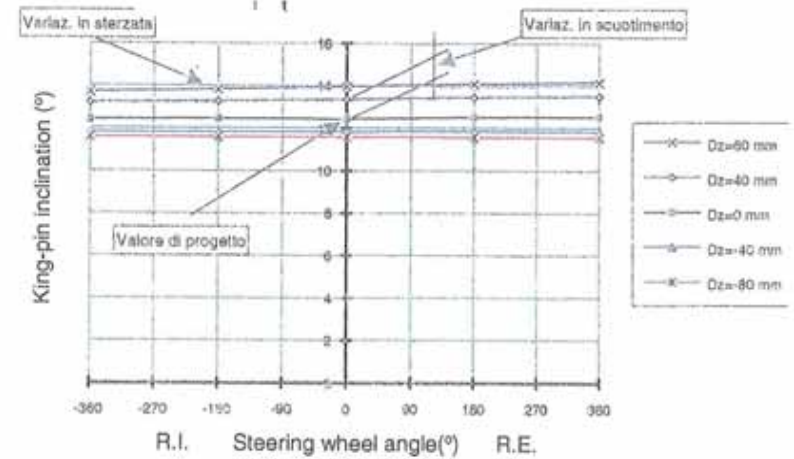
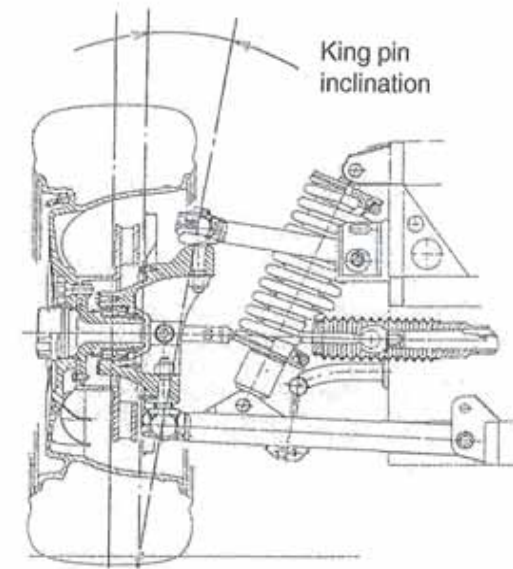

KING PIN INCLINATION

TOE CURVES vs WHEEL TRAVEL

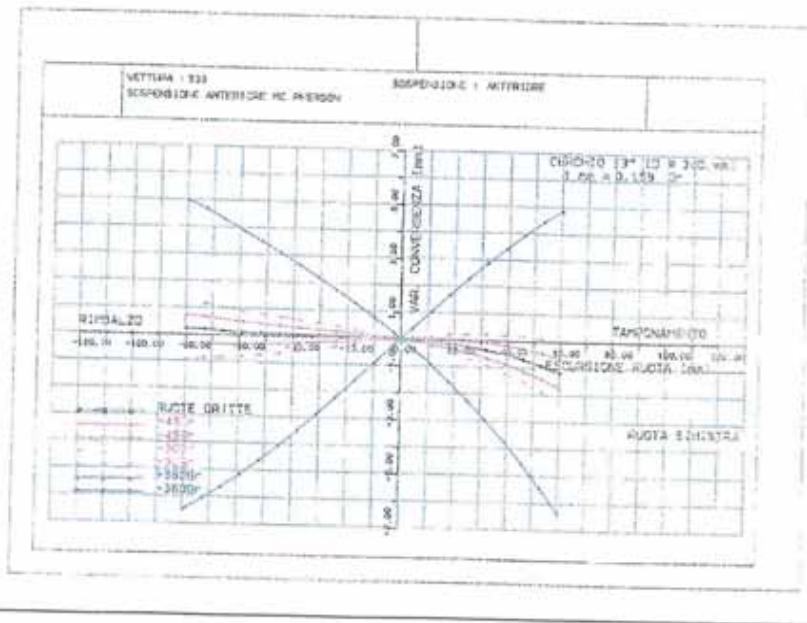
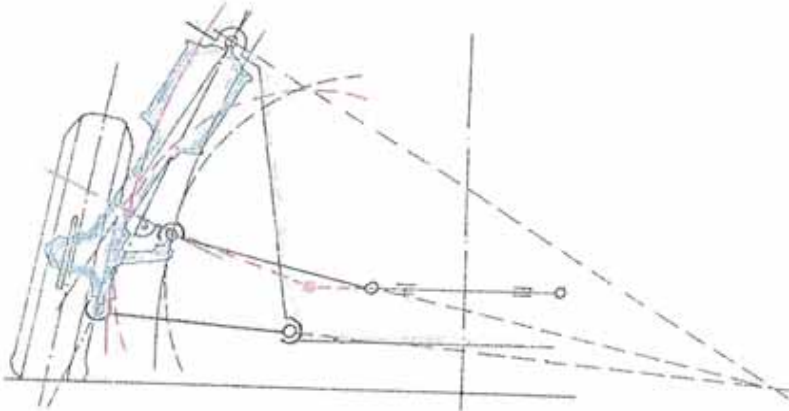

KING PIN INCLINATION

KING PIN INCLINATION INITIAL VALUE INFLUENCES:

- Scrub radius value
- Bump toe variation curves amplitude
- Steering wheel back at low lateral acceleration due to the vertical load

VARIATION IN KINEMATIC RIDE HEIGHT INFLUENCES:

- Scrub radius value variation
- Braking steering wheel force

KING PIN INCLINATION

STEERING WHEEL SYSTEM INFLUENCE ON TOE CURVES

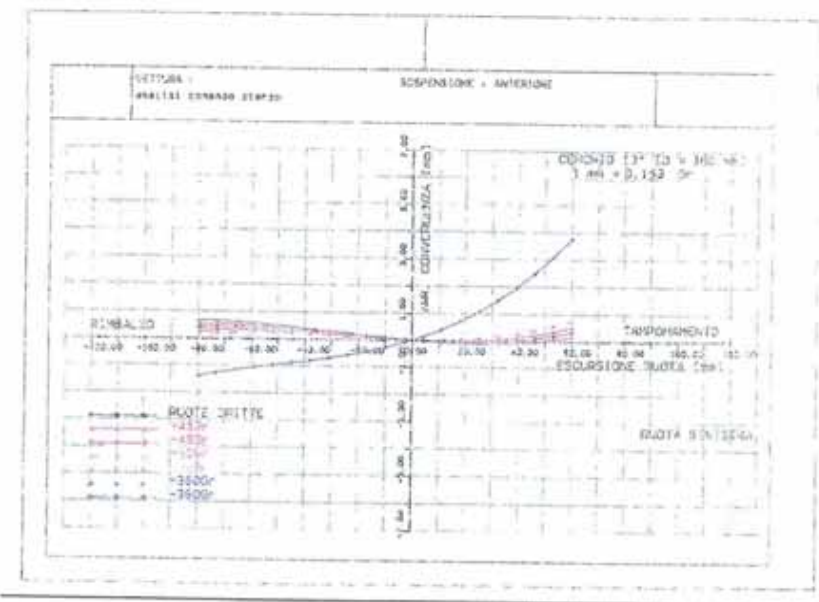
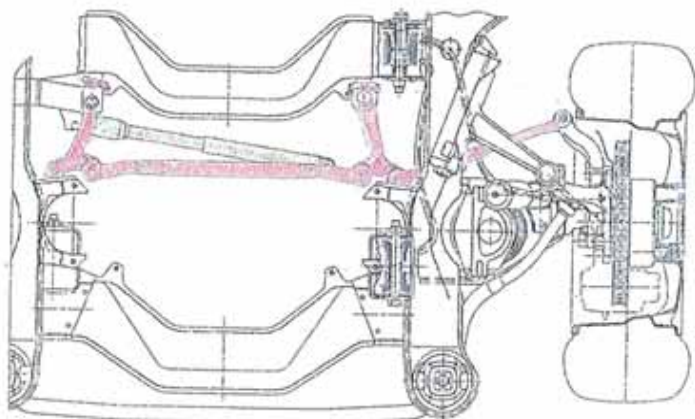

MECHANICAL TRAIL

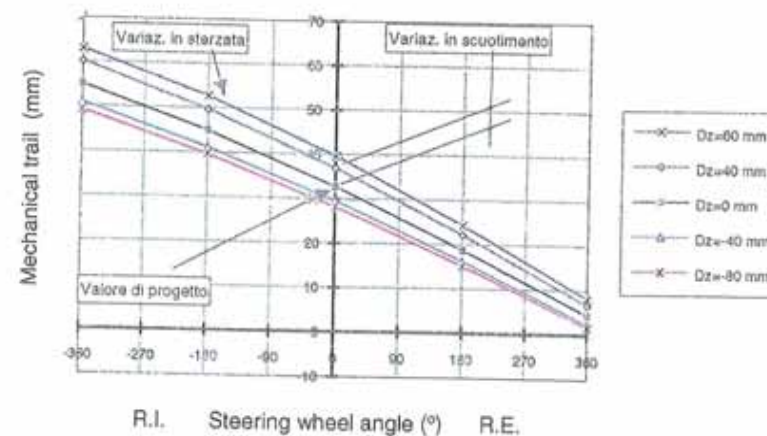
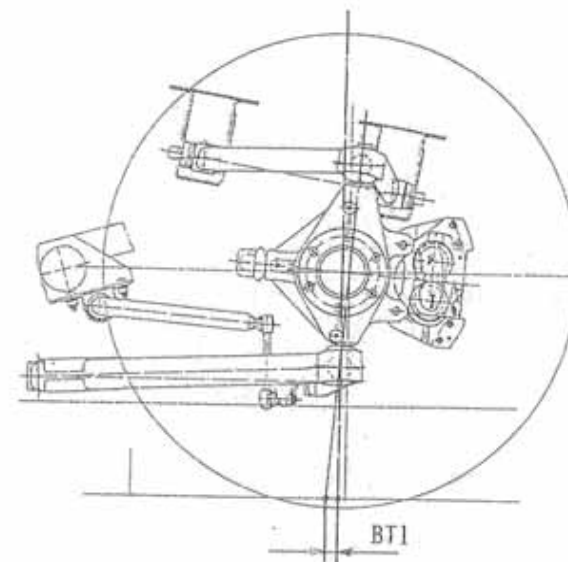

MECHANICAL TRAIL

MECHANICAL TRAIL INITIAL VALUE INFLUENCES:

- Wheel stability in straight path
- Lateral load contribution to the steering wheel trim force

VARIATION IN KINEMATIC RIDE HEIGHT AND IN STEERING INFLUENCES:

- Ground adhesion level sensor system quality
- The variable to be monitored by steering wheel trim force (lateral force or aligning torque)
- Wheels different contribution to steering wheel trim force (external/internal)
- Steering wheel trim force value on curves with variable radius

MECHANICAL TRAIL VARIATION

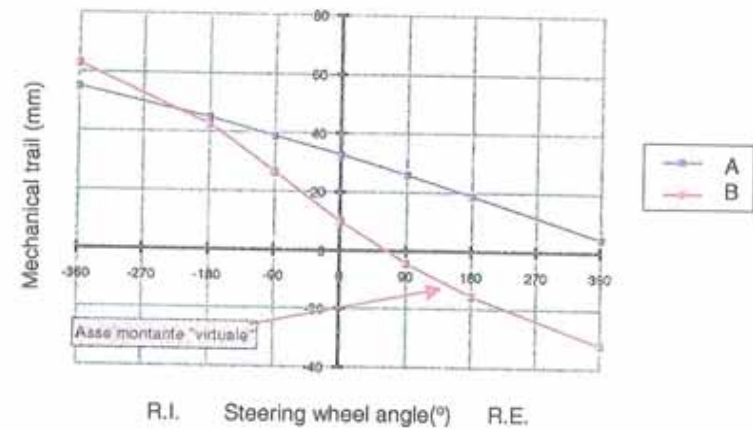

MECHANICAL TRAIL EFFECT ON THE STEERING WHEEL TORQUE

STEERING-PAD Radius = 100 m

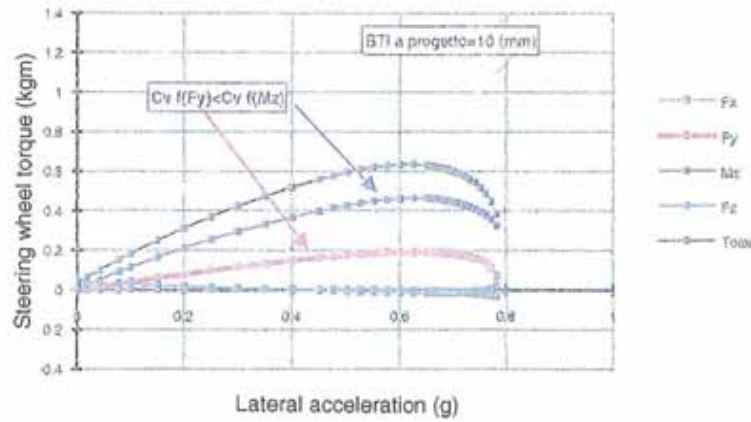
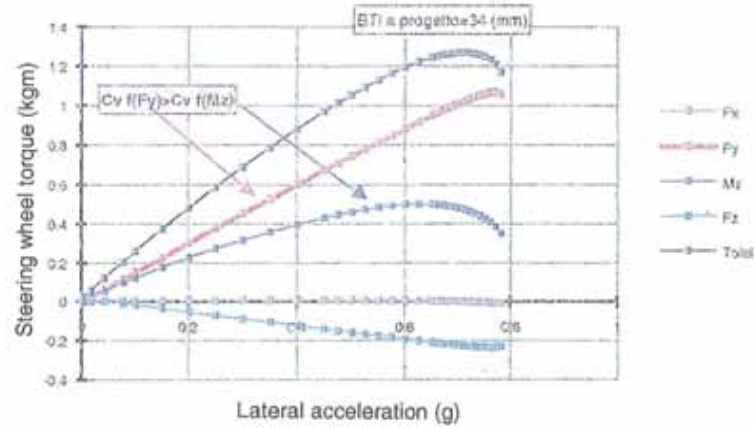

SCRUB RADIUS

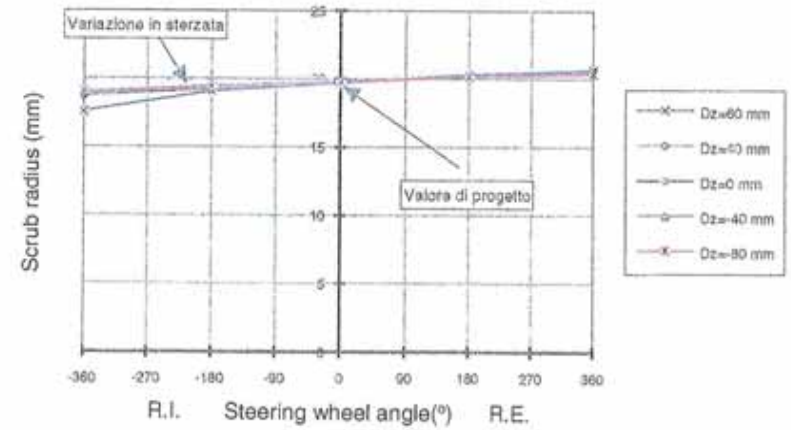
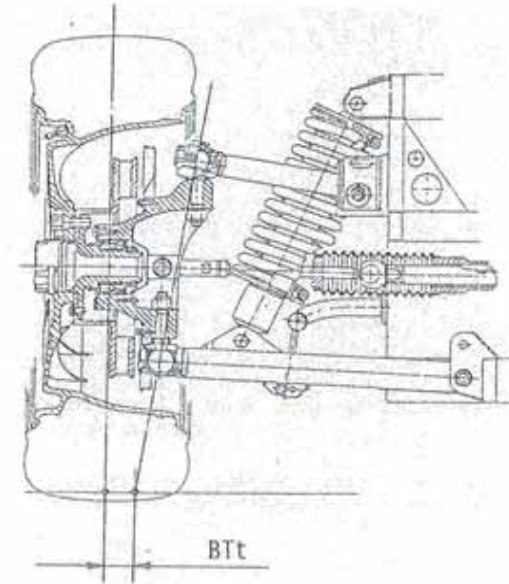

SCRUB RADIUS

SCRUB RADIUS INITIAL VALUE INFLUENCES:

- King-pin axis torque value in bracking, i.e. steering system components loads value
- Steering wheel torque value and versus in cornering braking
- Car stability in braking in split condition or with crossed braking system circuit in breakdown

VARIATION IN KINEMATIC RIDE HEIGHT AND IN STEERING INFLUENCES (virtual king-pin axis):

- Steering wheel torque value and versus in cornering braking

STEERING WHEEL TORQUE IN CORNERING BRAKING

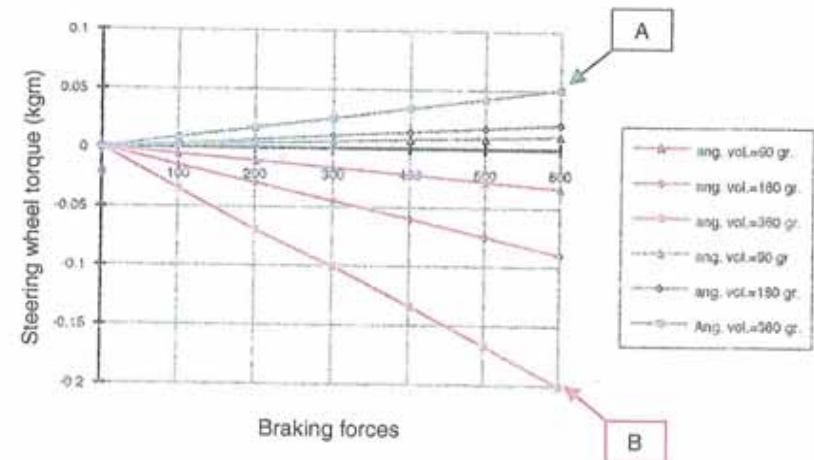
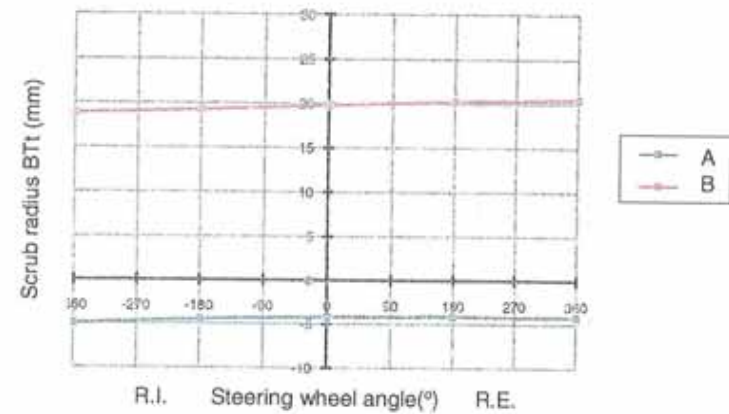

"e" LEVER ARM

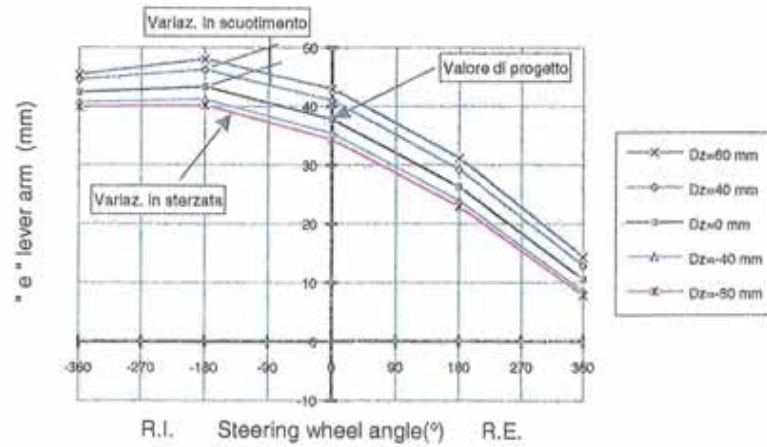
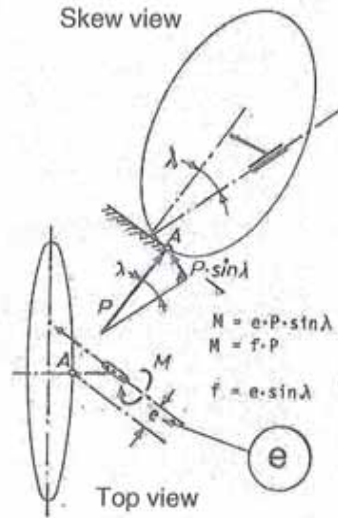

"e" LEVER ARM

"e" LEVER ARM INITIAL VALUE INFLUENCES :

- Steering wheel torque value due to load transfer between the axle wheels in straight path

VARIATION IN KINEMATIC RIDE HEIGHT AND IN STEERING INFLUENCES :

- Steering wheel torque evolution with steered wheels (steering cone)
- Steering wheel torque evolution due to load transfer

SCRUB RADIUS AT CENTERLINE

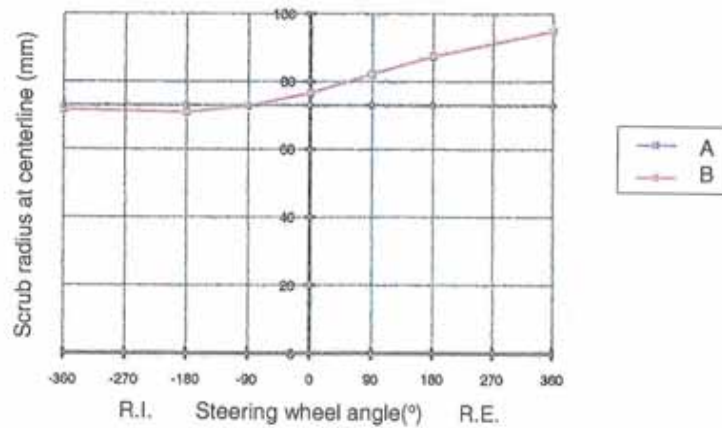
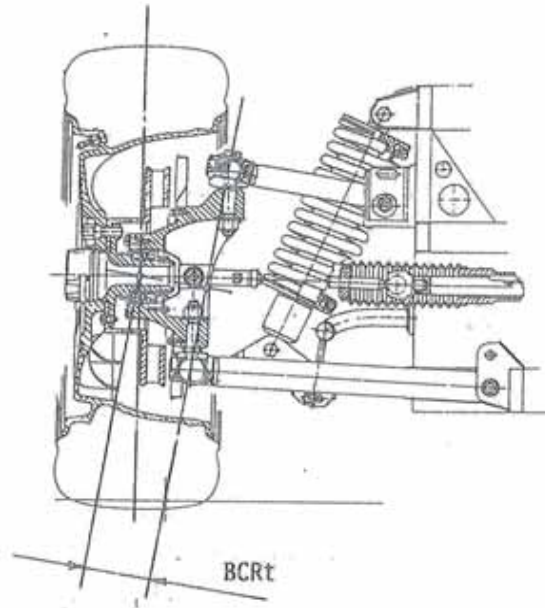

SCRUB RADIUS AT CENTERLINE

INITIAL VALUE OF SCRUB RADIUS AT CENTERLINE
INFLUENCES:

- King-pin axis torque value in traction, therefore steering system components load value
- Variation of steering wheel torque in fast start and grip loss
- "kick-back" effect when the wheel pass over an obstacle
- Steering wheel vibration, called "flutter", usually due to tyre unbalance

VARIATION IN KINEMATIC RIDE HEIGHT AND IN STEERING
INFLUENCES (virtual king-pin axis):

- Steering wheel back due to traction

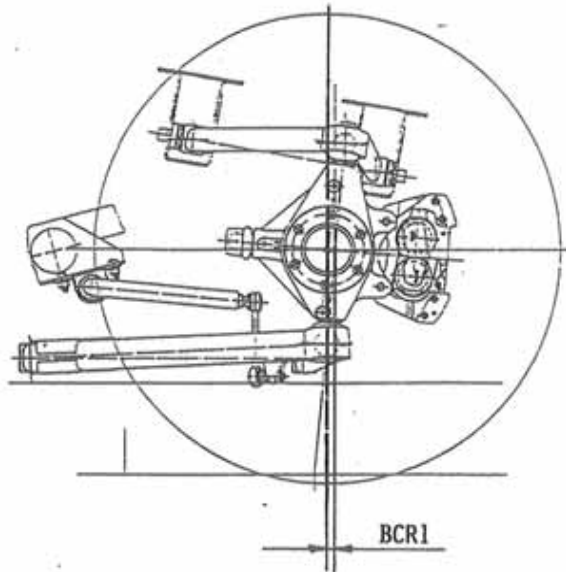
KING-PIN OFFSET**KINGPIN OFFSET INFLUENCES:**

- longitudinal ground arm value independently of caster angle value
- axle shaft pumping in cornering
- king-pin axis torque due to lateral acceleration applied to steering masses

Ackerman Error

ACKERMAN ERROR

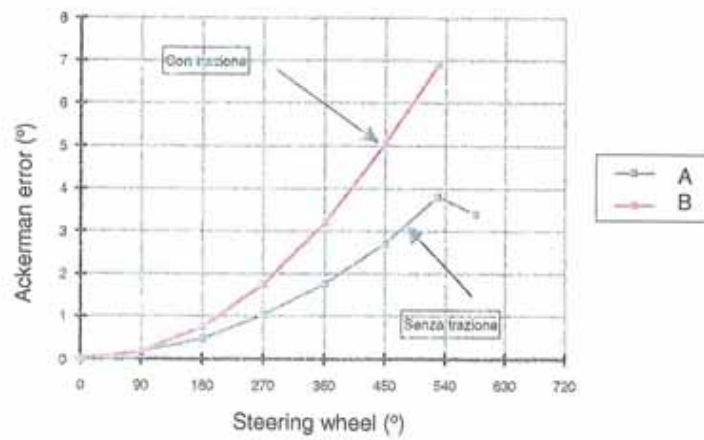
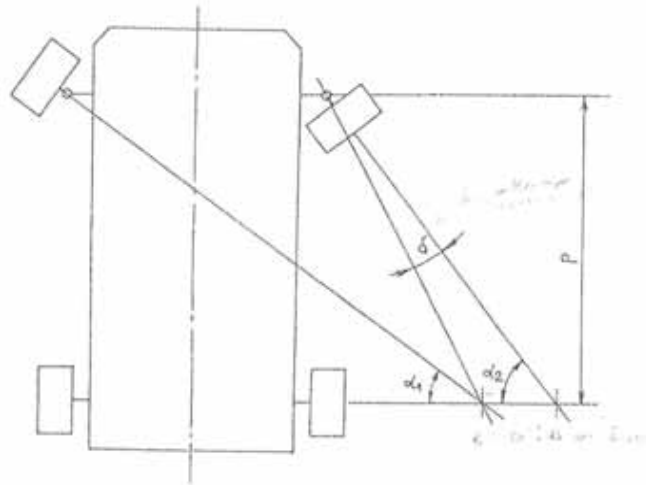

ACKERMAN ERROR EFFECT ON STEERING WHEEL TORQUE

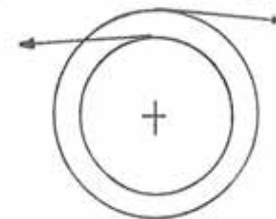
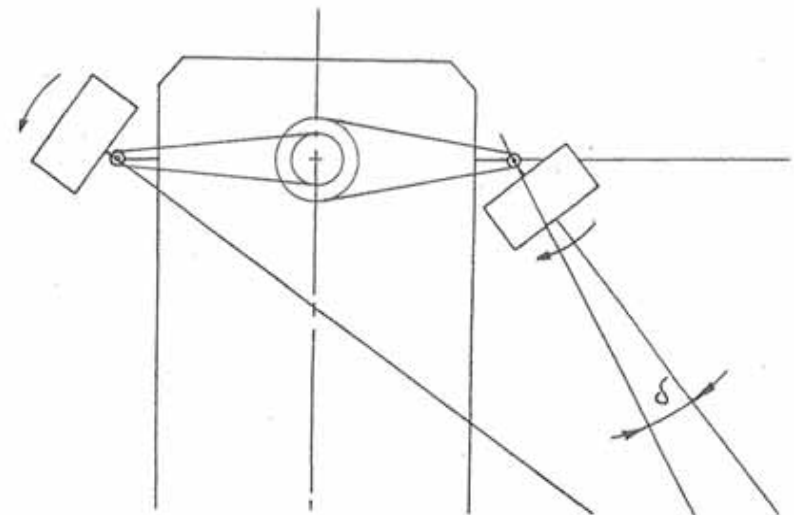

ACKERMAN ERROR

ADVANTAGES RELATED TO LOW ACKERMAN ERROR:

- Reducing wheels sliding on the ground during the manoeuvres
- Reducing lateral forces which lighten steering wheel force on small radius curves
- Making easier steering wheels back related to vertical and longitudinal traction loads

DISADVANTAGES:

- At high lateral acceleration, the inside front tire is forced to higher slip angle, causing tire wear
- With positive scrub radius, self-steering effect occurs under braking longitudinal load

Steering Wheel Systems

"SEMI-VIRTUAL" KING-PIN AXIS

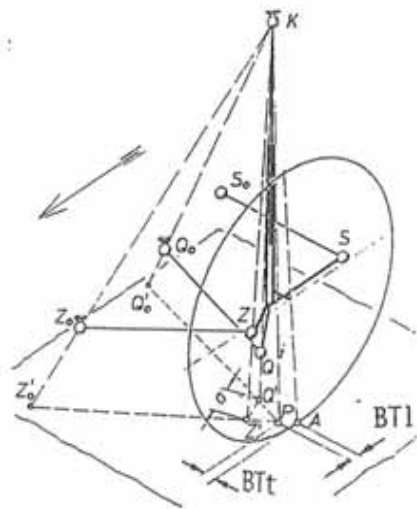
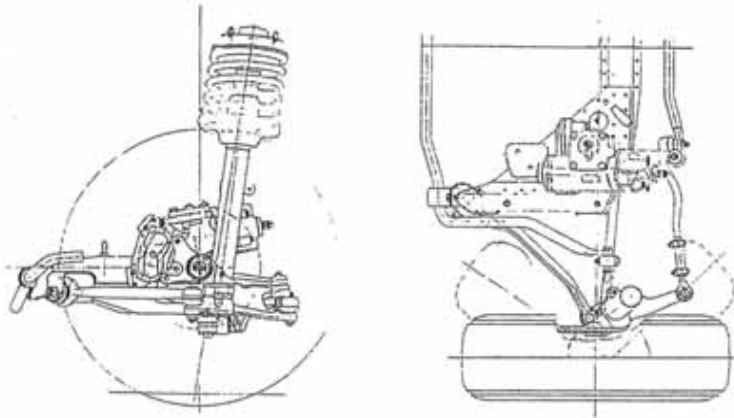

KING-PIN GEOMETRY

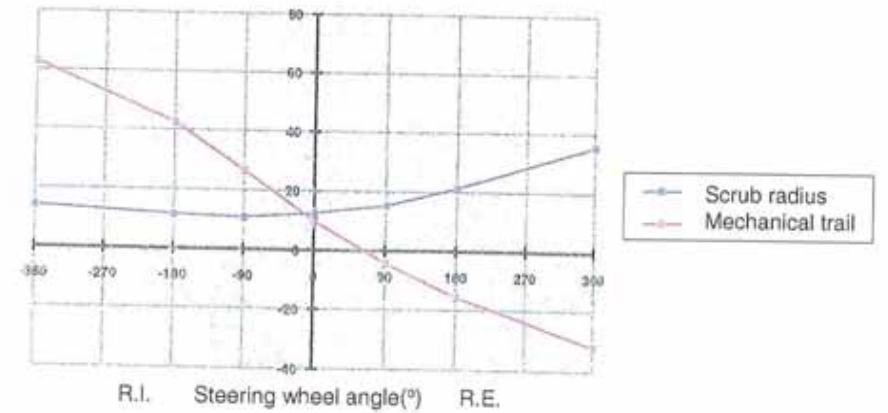
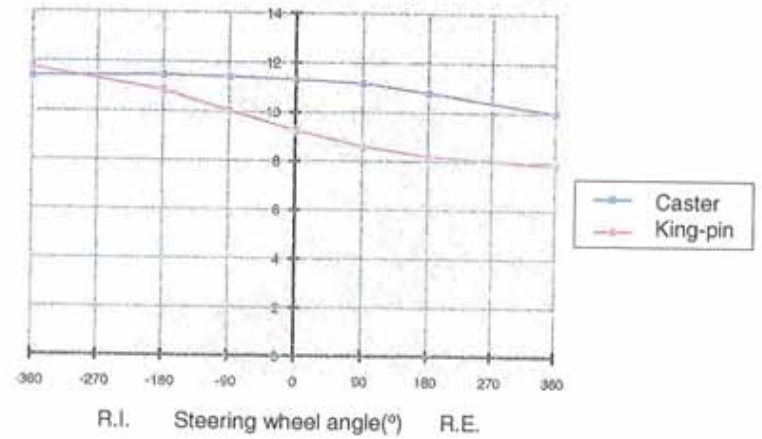

"VIRTUAL" KING-PIN AXIS

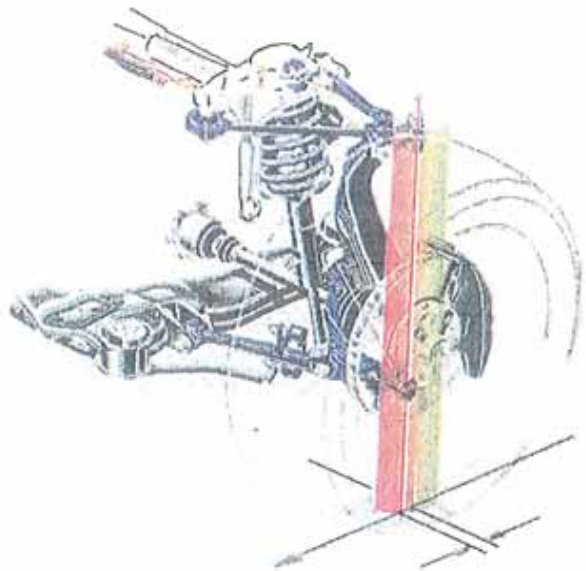

RACK WITH LATERAL EXIT

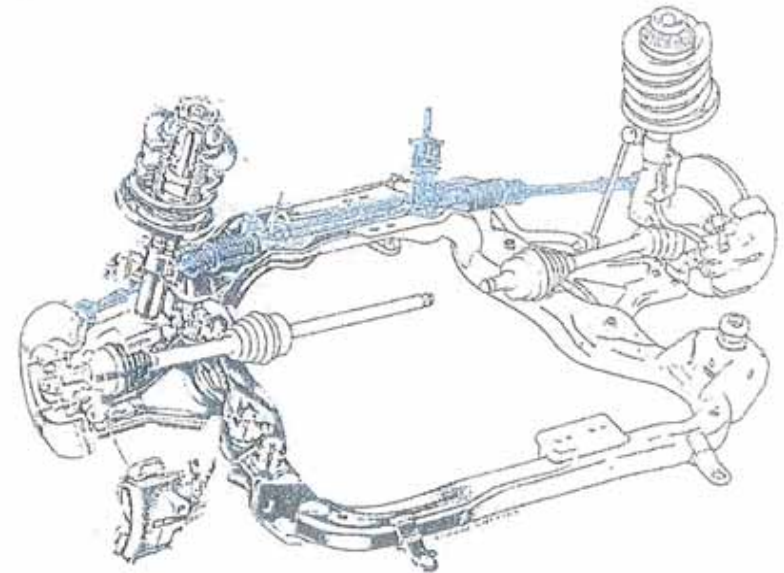

ADVANTAGES:

- Easy manufacturing
- Small dimensions suitable for transversal engine

DISADVANTAGES:

- Compliance and imprecision of the command
- Large toe variation with steered wheels in kinematic ride height

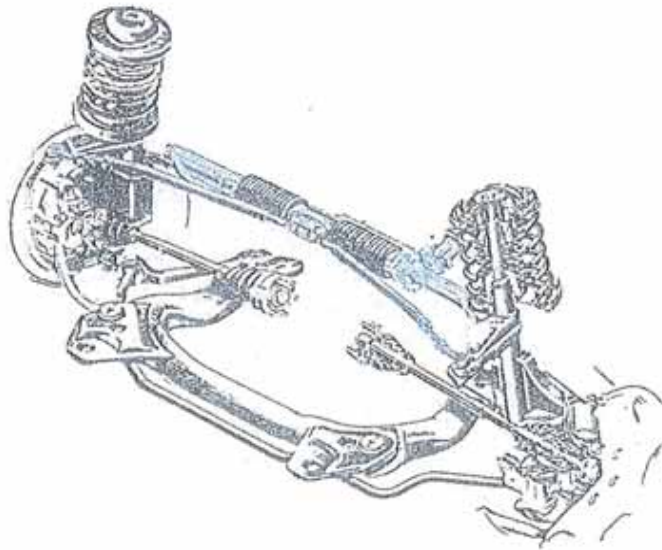
RACK WITH CENTRAL EXIT**ADVANTAGES:**

- Good adaptability for longitudinal engine
- Good toe variations control with steered wheels in kinematic ride height
- Structure suitable to keep constant displacements

DISADVANTAGES:

- More complex to manufacture with respect to the lateral exit solution

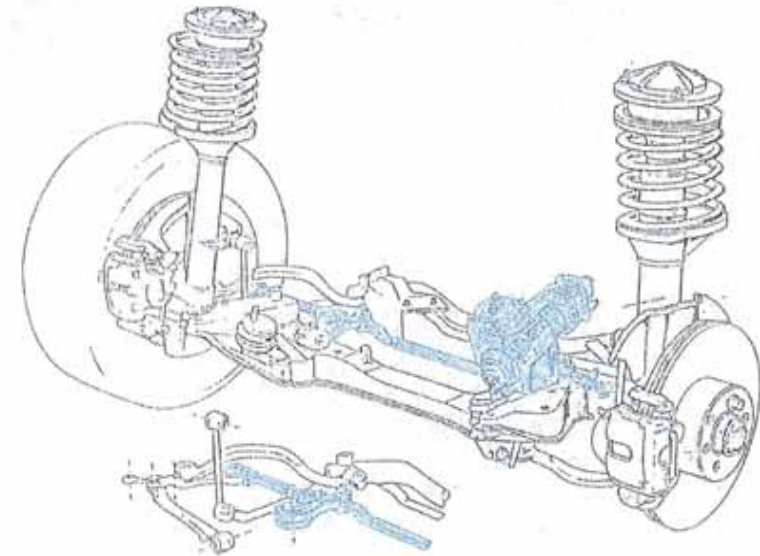
PARALLELOGRAM WITH WORM SCREW**ADVANTAGES:**

- Good toe variation control with steered wheels in kinematic ride height
- Good reversibility control

DISADVANTAGES:

- Cost element
- Large dimensions